

5

Setting Up the Polling Place

ELECTION DAY - 5:00 AM TO 6:00 AM

IMPORTANT:

The electronic poll book **MUST** be set up first and you **MUST** begin the update by 5:15 am.

■ ALL JUDGES OF ELECTION AND POLLING PLACE ADMINISTRATORS MUST REPORT TO THE POLLING PLACE NO LATER THAN 5:00 AM.

- Pollwatchers, with proper credentials, may enter at 5:00 am to view the setting up of the polling place.
- No one, including judges of election, may vote before 6:00 am.
- The polling place administrator will assist the judges with the setting up of the equipment and determining the setup of the polling place.

1. CHECK POLLING PLACE FOR A PORTABLE RAMP

Some polling places will have a ramp delivered in order to make it accessible to voters with disabilities. The ramp

will be put in place by the Board of Elections and will be in place by 5:45 am. Do not remove the ramp until the polling place closes at 7:00 pm.

2. OPEN THE ESC

- A. Make sure that the ESC delivered is for your assigned precinct and ward. Check the labels on the ESC, which indicate the precinct and ward.
- B. Using the seal cutters (which were given to both the key judge and the polling place administrator in the envelopes picked up prior to Election Day), break the seal on the ESC doors (**do not throw away the seal, it must be verified and returned in the Broken/Used Seal Bag**).
- C. Using the ESC key, unlock the door and remove the key. In order to open the door, push on the area where the key was inserted. This will release the latch and open the doors. Do not break the lock on the ESC.
- D. Remove the Seal Accountability Form, located in the plastic sleeve on the ESC door, and verify that the seal number you just removed from the ESC door is the same seal number that appears on the Seal

Accountability Form. **If the seal number is not the same or if the seal is missing, you must call EQUIPMENT/SUPPLIES at 773-247-4065 IMMEDIATELY.**

- E. Place the broken, used seal inside the Used Seal Bag.
- F. Place the flag at the door of the polling place.

3. CHECK THAT YOUR ESC CONTAINS THE EQUIPMENT AND SUPPLIES FOR YOUR PRECINCT AND WARD

The Supply List (Form 21) is located on the ESC door, as well as, on page 11.

4. LOCATE TABLES AND CHAIRS

If there are no tables and chairs, contact the Polling Place Department at 312-269-7976 immediately. Arrange tables and chairs and the voting supplies and equipment so that you can easily manage the flow of voters and voter privacy is maintained. Please consider the mobility of voters who use a wheelchair and other assistive devices when you set up the tables and chairs.

5. JUDGE OF ELECTION OATH OF OFFICE AND BADGE

Read and sign the Oath of Office for Assigned Judges (Form 9). Wear the badge of the political party you are representing. Fill in your name and the precinct and ward where you are working. You must wear the badge for the duration of the day. Swear-in judges must complete the checklist and sign the Application For Swear-In Judge of Election and Oath of Office, Form 4. The assigned judge of election who administers the oath to the swear-in judge must follow the procedures indicated on the Form 4, including calling the Board of Elections and verifying the swear-in judge's eligibility.

6. POLLING PLACE ADMINISTRATOR BADGE

The PPA must fill in his or her name and precinct (s) and ward(s) where they are working. The badge must be worn for the duration of the day.

7. CAMPAIGN FREE ZONE MATERIALS

- 2 - 18" Blue Cones
- 100 foot cord

Each polling place will have the Campaign Free Zone materials delivered to it in the ESC. In a polling place with more than one precinct, only one set of materials will be provided.

Immediately call EQUIPMENT/SUPPLIES at 773-247-4065

- If you do not have a key to the ESC. Do not attempt to break the lock.
- If any supplies are missing.
- If you do not have the correct equipment.

SUGGESTED POLLING PLACE ARRANGEMENTS

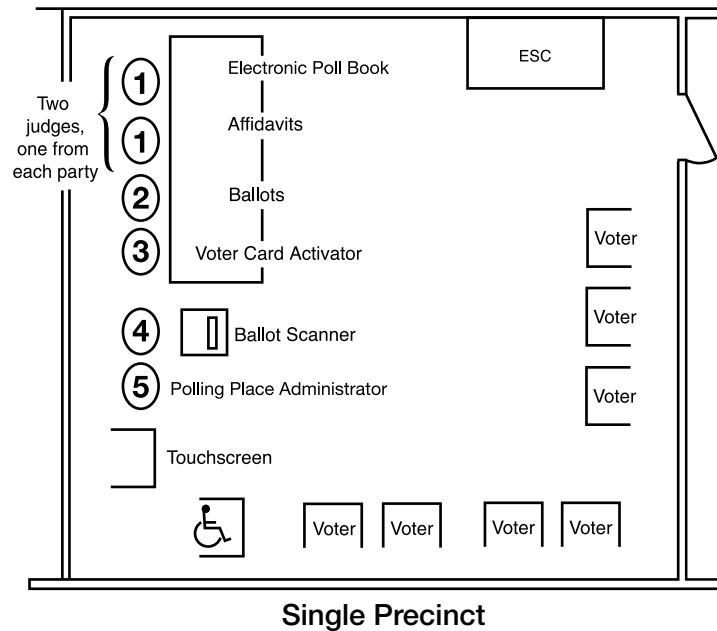

ELECTION CENTRAL
 Legal, investigative, procedural
 and language assistance
(312) 269-7870
 (Election Day only 5:00 am –
 10:00 pm)

EQUIPMENT/SUPPLIES
 Problems with equipment or
 missing supplies
(773) 247-4065
 (Election Eve (Monday)
 5:00 pm – 7:00 pm,
 Election Day 5:00 am – 10:00 pm)

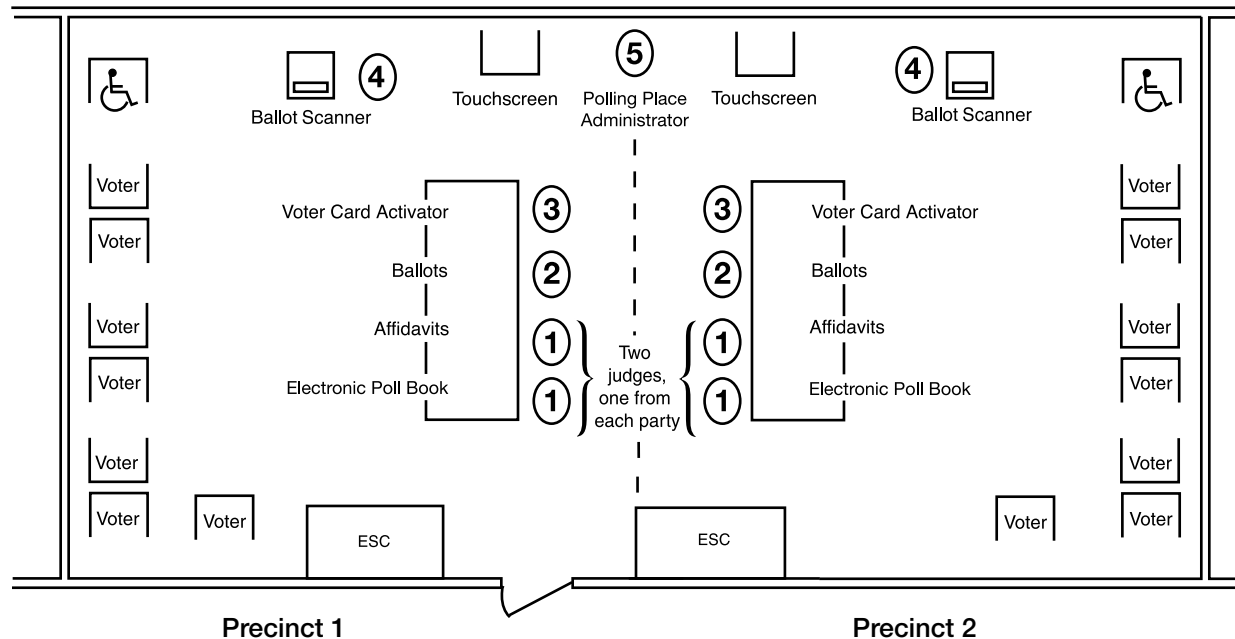

Both the judge of election and polling place administrator must determine the layout of the polling place. Remember to set up the voting booths so that voter privacy can be maintained. Please keep voter accessibility in mind; avoid setting up equipment where it is difficult for voters with disabilities to access it.

Tables and chairs should be available to you. If you cannot locate the tables and chairs, call the Polling Place Department at 312-269-7976 immediately.

THE ELECTRONIC POLL BOOK & ACCESSORIES

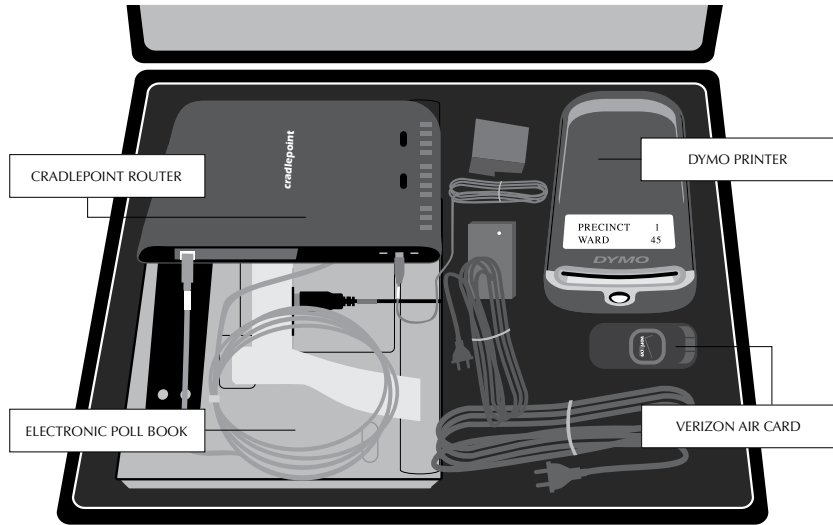

8. SET UP THE ELECTRONIC POLL BOOK

The electronic poll book will allow the judges of election to search registered voters in the precinct and check them in electronically. Connecting devices are denoted by color.

A. PLUGGING IN ELECTRONIC POLL BOOK & ACCESSORIES

1. Confirm correct e-poll book was delivered. Check tag on the handle of the case.

2. Using the Seal Accountability Form, verify seal number on latch of case. If seal numbers match, break seal and place in used seal bag. If seal numbers do not match, call Equipment & Supplies immediately.

Equipment & Supplies:
773-247-4065

3. Remove all contents from case.

4. Locate e-poll book. Confirm seal number on the memory card cover. Notice three cords already plugged into the back. Use the stand on the back to set it upright.

Plug grey cord (YELLOW) into the Cradlepoint router.

5. Plug USB cord (BLUE) into bottom of Dymo printer.

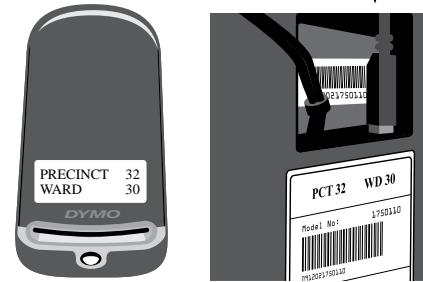

6. Locate the Verizon Air Card. To open, rotate cover clockwise. Plug into port 1 on the side of the Cradlepoint router (ORANGE).

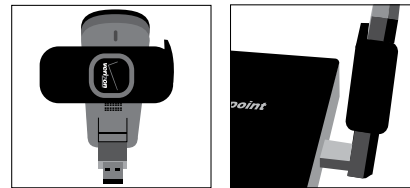

7. Plug power cords from e-poll book (RED), printer and router into power strip (found in the ESC). When the printer is plugged in, it turns on automatically, signaled by the blue light on the front of the unit.

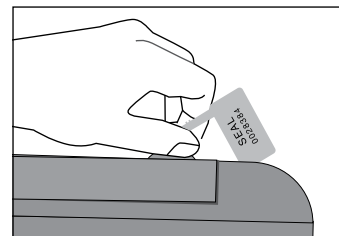

B. POWERING ON THE CRADLEPOINT ROUTER

1. Ensure router is plugged into the power strip and that the Verizon Air Card is fully plugged into port 1.
2. Ensure the e-poll book is turned OFF.
3. On the Cradlepoint router, switch the power to the ON position. The – side of the switch will be flush with the device.
4. The lights on the top of the unit will flash, green, orange, red, and blue.
5. The Verizon Air Card light will flash blue.

The unit will take up to 5 minutes to initialize and connect. Do not turn on the e-poll book during this period.

6. The unit is connected when the power light and the light above 1 are green. The diagonal bars will be blue. If not every bar is lit, it means the signal isn't at full strength. This is OK. You may now turn on the e-poll book.

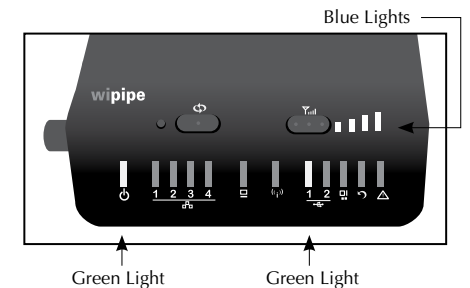

C. LAUNCHING E-POLL BOOK

1. Power on the e-poll book (only after the router is connected).
2. It will take a few seconds for the launch screen to appear. From the Launch screen, tap the Launch Express Poll Button with the stylus.
3. Always follow the instructions on the screen.

Enter the password found in the e-poll book case. Tap **Continue**.

4. Follow the instructions on the screen.

Ensure the precinct and ward are correct. Type your initials and the password again. Tap the **Log In** button.

Remember: As judges rotate duty stations throughout the day, it is important to log out and log back in using the new judge's initials.



5. Verify precinct information is correct. Tap **OK This is Correct Poll**. If incorrect, call Election Central.

6. Confirm statistics are all at zero. The numbered of Registered Voters will not be zero.

D. MORNING UPDATE

1. Check for connectivity. Tap on the **Status** tab at the top right of the screen. Look at the bottom of the screen. If you see the word "Idle" or "Synchronizing", this means the poll book is connected. Proceed to Step 2. If you see the word "Connecting" or "Error", the poll book is not connected. Proceed to page 73 for troubleshooting instructions.
2. Tap on the **Poll Book Update** tab and the **Poll Book Update** button at the bottom of the screen.
3. Tap the **Run Update** button.
4. The e-poll book will update its files with new voter information.

5. Once complete, the message will read "Smart Update Complete, — records updated. Tap OK.



6. Now you must power off the e-poll book.
Power the unit on again.
Re-launch the e-poll book and enter your user initials and password.

E. OPENING THE POLLS ON THE E-POLL BOOK

1. Once again, verify that the statistics are all set to zero and the Poll Book Update shows today's date.
2. Remember, on the right side, **Registered Voters** will NOT be zero
3. Tap the **Open the Poll Book** button.
4. The **Poll Status** will change to green and display "**OPENED**".

F. VOTER NAME SEARCH

1. Tap the Issue Ballots tab at the top of the screen.

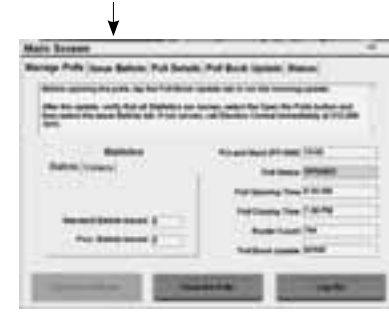

2. Tap the Continue button.



3. **Congratulations!**

The e-poll book is ready for voter check-in.

9. ASSEMBLY OF METAL VOTING BOOTHS

Every ESC will contain metal and plastic voting booths. Space permitting in the polling place, you should set up every booth.

- A. Remove all metal voting booths from the ESC.
- B. Place the booth on a table with the Board of Elections sticker facing up and open the case.
- C. Remove the legs from the lid. Close and lock the lid.
- D. Put each leg section together.
- E. Turn the case over on the table. Insert the legs, one at a time, into each hole on the bottom of the booth. Push the legs in tightly using twisting motion until snug.
- F. Pick up the booth, turn it over and stand on legs. Open the lid, lift and secure the side panels. Unwrap the electrical cord and plug the metal voting units into each other (there are receptacles on the side of each unit). Plug the last cord into a wall outlet or extension cord.
- G. The Voting Instructions Sign, Form 255, is attached to the privacy screen. If it is not, remove Form 255 from Envelope 2 and tape it to the privacy screen.

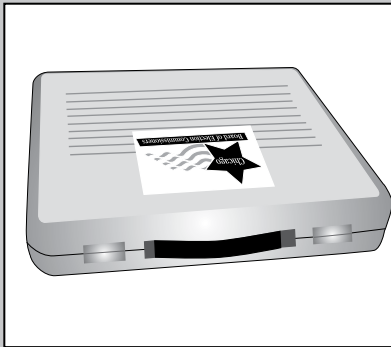

18-A/B

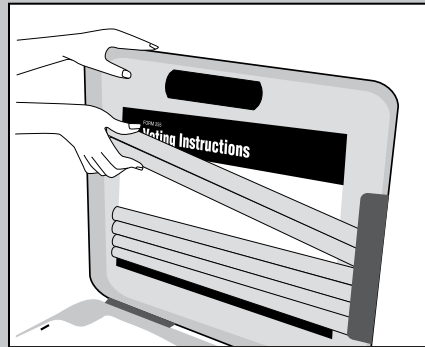

18-C

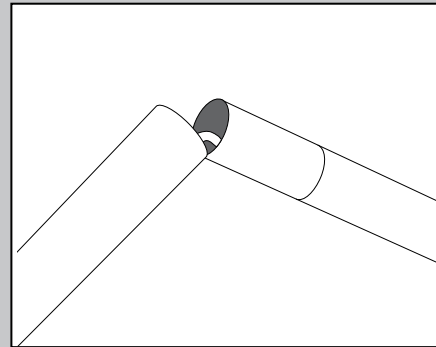

18-D

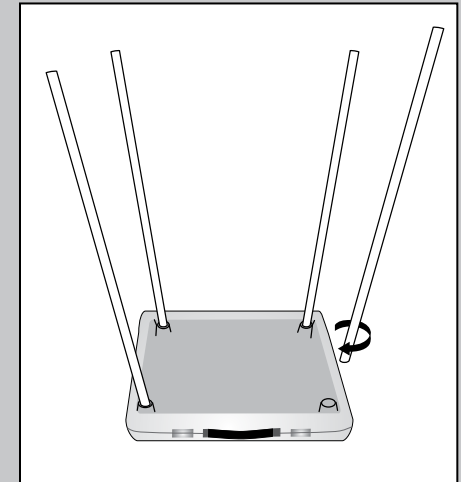

18-E

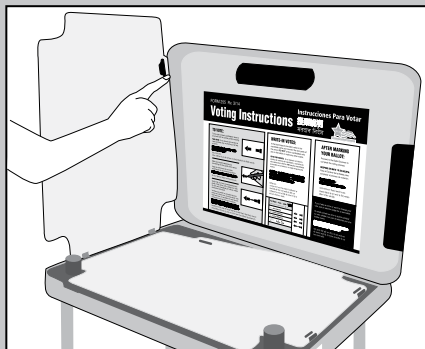

18-F

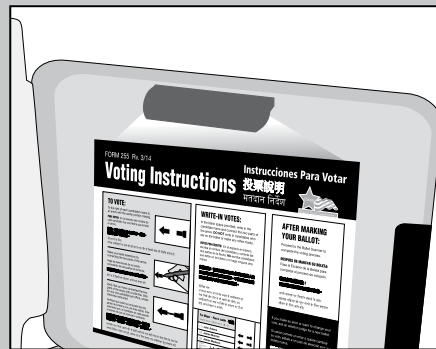

18-G

10. ASSEMBLY OF PLASTIC VOTING BOOTHS

- A. Remove all plastic voting booths from ESC.
- B. Place a booth on a table with the Board of Elections sticker facing up; open the case.
- C. Remove the legs from the lid, then close and lock the lid.
- D. Put each leg section together.
- E. Turn the case over on the table. Insert the legs, one at a time, into each hole on the bottom of the booth. Push the legs in tightly using twisting motion until snug.
- F. Pick up the booth, turn it over and stand on legs. Open the lid, lift and secure the side panels. Unwrap the electrical cord. To the right of the light unit there is a receptacle that can be used to connect the units together. Plug the booths into each other and plug the last booth into a wall outlet or extension cord.
- G. The Voting Instructions Sign, Form 255, is attached to the privacy screen. If it is not, remove Form 255 from Envelope 2 and tape it to the privacy screen.

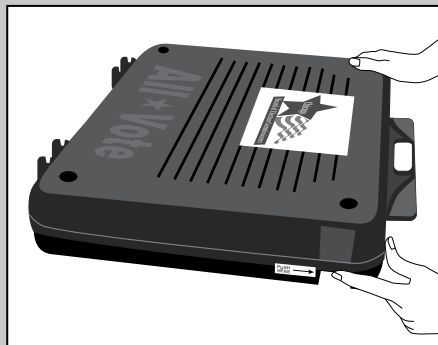

19-A/B

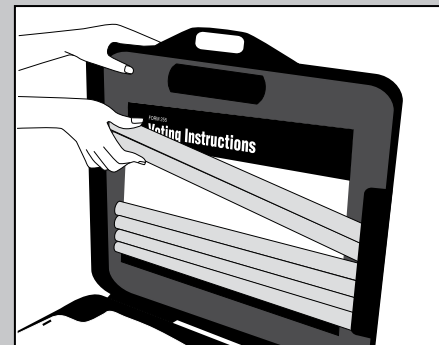

19-C

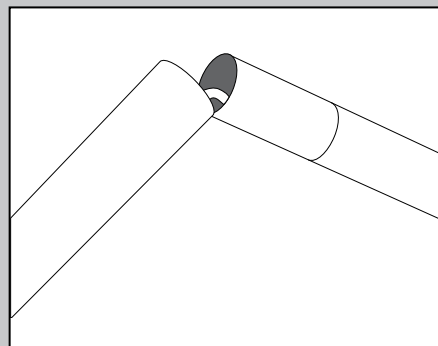

19-D

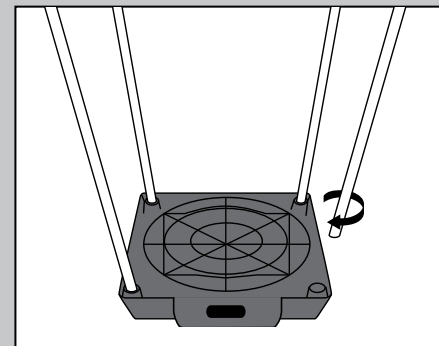

19-E

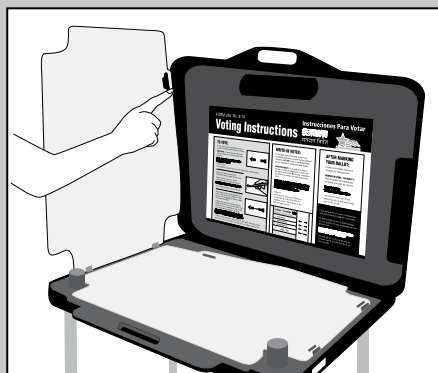

19-F

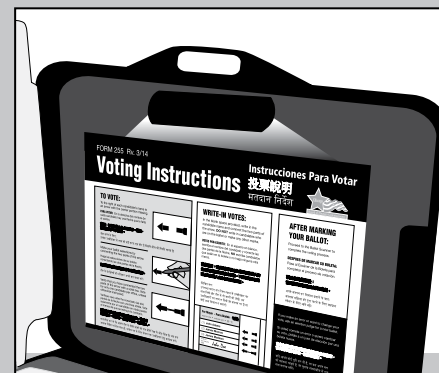

19-G

NEW**11. ASSEMBLY OF LOWERED VOTING BOOTH**

A lowered voting booth, specifically designed for use with a chair or wheelchair, must be assembled and available for any voter's use. The lowered voting booth is made of grey plastic.

- A. Remove the grey plastic case and place the booth on a table with the Board of Elections sticker facing up; open the case.
- B. Remove the legs and plastic extenders from the lid, then close and lock the lid.

- C. Put each leg section together.
- D. Turn the case over on the table. Insert the extenders in the holes at the front of the booth (the side with the handle).

Insert the legs, one at a time, into the two holes on the bottom of the booth and the two holes in the extenders. Push the legs in tightly using twisting motion until snug.

- E. Pick up the booth, turn it over and stand on legs. Open the lid, lift and secure the side panels. Unwrap the electrical cord. To the right of the light unit there is a receptacle that can be used to

connect the units together. Plug the booths into each other and plug the last booth into a wall outlet or extension cord.

- F. The Voting Instructions Sign, Form 255, is attached to the privacy screen. If it is not, remove Form 255 from Envelope 2 and tape it to the privacy screen.
- G. Assemble the chair by pulling out on the arms and pressing down on the seat. Place chair and booth where a voter with a disability or elderly voter may use it. If needed, remove the chair to allow a voter using a wheelchair to use the booth.

- H. Do not allow voters to apply weight or lean on the voting booth.

12. ARRANGE THE VOTING BOOTHS IN THE POLLING PLACE

Put the open side of each voting booth towards a wall, if possible. (See diagram on page 15). It is important that each voter has privacy while voting. Plug in the electric cords and plug booths into each other. Make sure the electric cords will not cause a voter to trip and fall or impede the passage of a voter using a wheelchair. Use tape to secure the cords to the floor, if necessary.

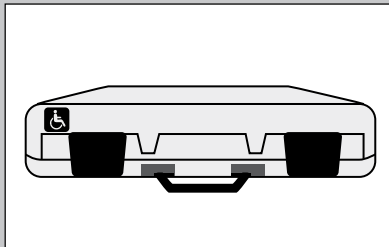

20-A

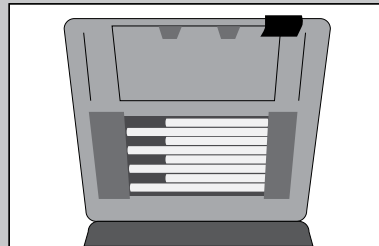

20-B (1)

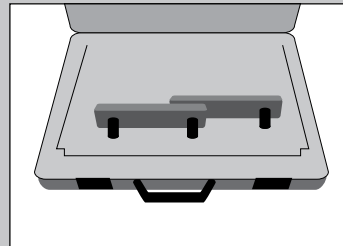

20-B (2)

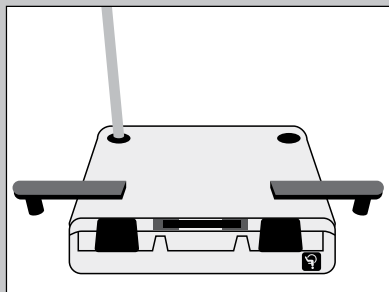

20-C

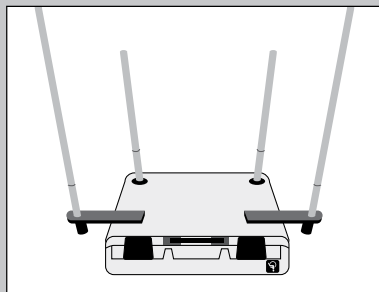

20-D

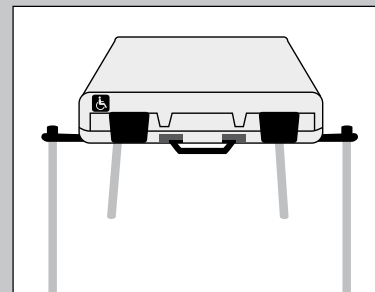

20-E (1)

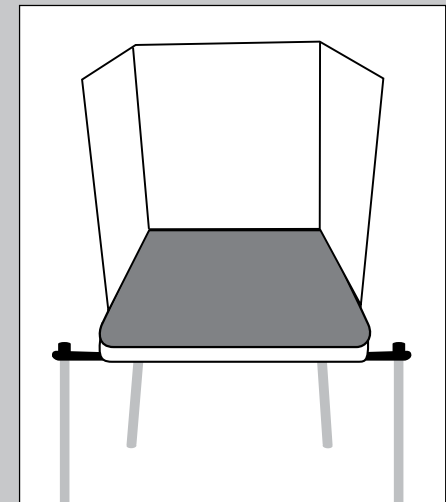

20-E (2)

13. ASSEMBLY OF THE BALLOT BOX FOR THE BALLOT SCANNER

The components for the ballot scanner ballot box are located in the ESC. Make sure to follow the instructions and illustrations shown so that the ballot box and ballot scanner are set up correctly.

- A. Remove the three components (top, bottom and collapsible body) from the ESC.
- B. Place the bottom of the box on the ground.
- C. Unfold the collapsible body into a box and place on bottom. Secure the bottom to the body by using the Velcro straps. **The white arrow and the Board seal are on the front of the box.**
- D. Place the top of box on the body. The white arrow on the top must line up with the white arrow on the body.
- E. Secure the top to the body by using the Velcro straps.
- F. Place ballot scanner on the top of the ballot box making sure that the front of the ballot scanner is facing the front of the ballot box.
- G. **SECURE THE BALLOT SCANNER TO THE BALLOT BOX BY USING THE SEALS LOCATED INSIDE**

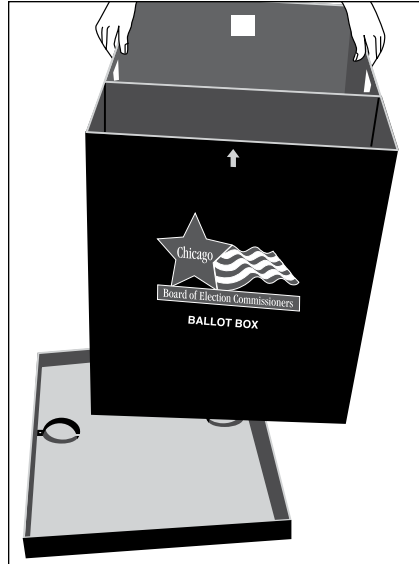

21-C (1)

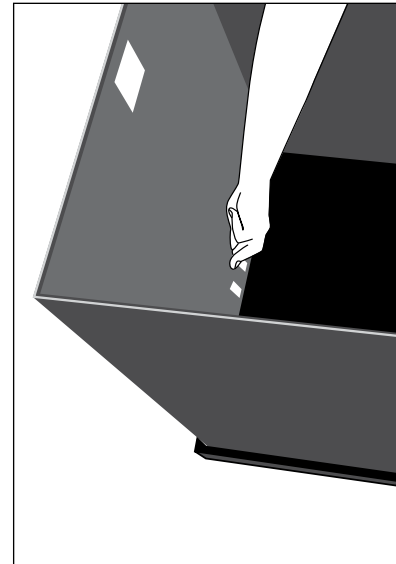

21-C (2)



21-D

THE UNUSED SEAL BAG. Remove two seals from the Unused Seal Bag. Secure the ballot scanner to both sides of the ballot box by threading the seal through the two holes located on the top of the ballot box and then through the cable tie that is attached to both sides of the ballot box. **You must record the seal numbers on the Seal Accountability Form.** Remember to place the broken/used seals in the Used Seal Bag.



21-F

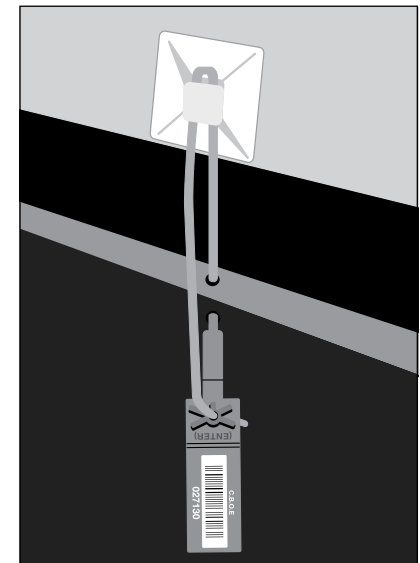

21-G

The arrows on the top and body of the ballot box must be pointing together and the front of the ballot scanner must face the front of the ballot box.

14. SET UP THE BALLOT SCANNER

Ballot Scanner must remain plugged in ALL DAY! If there is a power outage, immediately call ELECTION CENTRAL at 312-269-7870.

The ballot scanner has a public counter, a paper tape and keypad. The public counter will count the number of ballots accepted by the ballot scanner, and the paper tape will display messages and instructions to the judges of election. The keypad is located on the back of the ballot scanner (underneath the door).

- A. Remove the ballot scanner key from the blue supply box. Unlock the rear door of the ballot scanner and verify that the seal number

located on the seal affixed to the memory pack door is the same as on the Seal Accountability Form. Do not break the seal at this point. **If the seal number is not the same or if the seal is missing, call EQUIPMENT/SUPPLIES at 773-247-4065 immediately.** If the memory pack door is slightly opened, push door closed. Make sure the power cord is plugged into the rear of the ballot scanner. Close the rear door of the ballot scanner and return the key to the blue supply box in the ESC.

- B. Plug the power cord into extension cord, if necessary, and then into 3-hole electrical outlet. If the precinct does not have a 3-hole outlet, plug the cord into the special adapter, found in the grey supply box, and then into a 2-hole electrical wall outlet.
- C. As soon as the ballot scanner is plugged in, it will begin operating. Make sure the red power light (on the front of scanner) is ON.

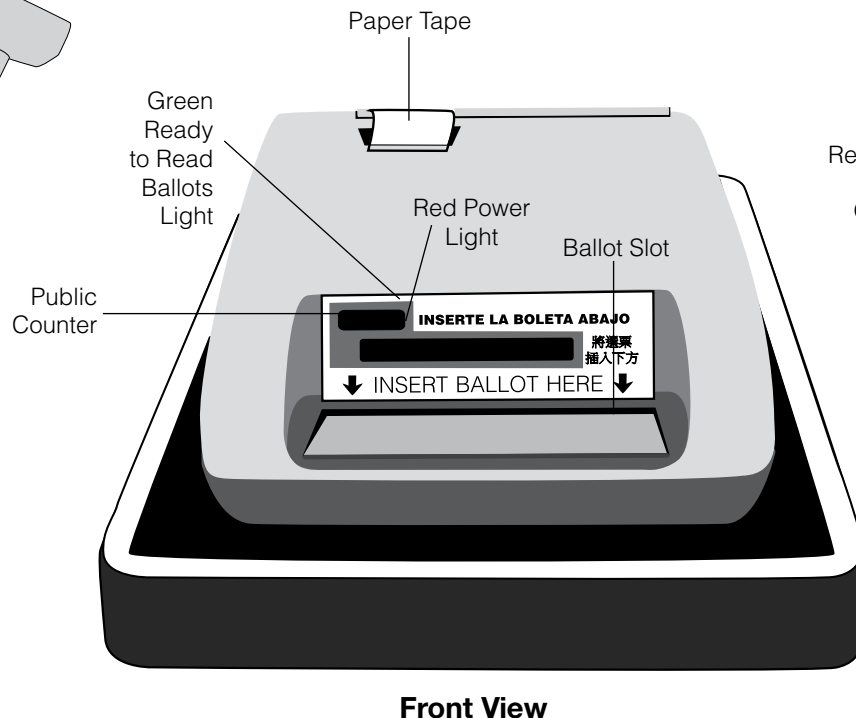
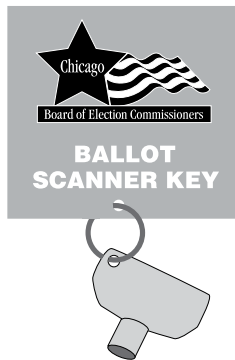

BALLOT SCANNER

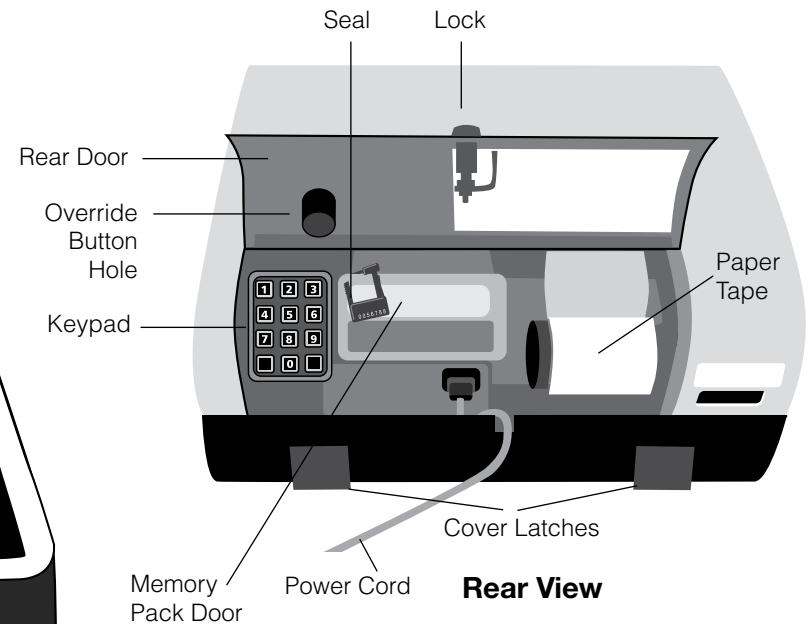

(THE MEMORY PACK WILL BE INSIDE THE SCANNER UPON DELIVERY TO THE POLLING PLACE. AFTER THE POLLS CLOSE, THE BALLOT SCANNER MUST BE UNPLUGGED BEFORE REMOVING THE MEMORY PACK.)

SEQUOIA OPTECH INSIGHT

21st Century Optical Ballot Counting System!

HPX. K/K1. 42. 050816. 1100
HARDWARE DIAGNOSTICS PASSED

APX 2.12 050905. 1320
Insight serial number is 503,421
Protective counter number is 127

5:15:00 AM
5:15:10 ALL CHECKSUMS O.K.

ELECTION

Election parameter data created from
EMS database of 12:00:00 PM

5:15:11 AM

BALLOT REPORT

Insight serial number is 503,421
Protective counter number is 127

Precinct 0001
- COUNTED _____ 000
- NOT COUNTED _____ 000
= TOTAL BALLOTS CAST _____ 000

23-D/E

- D. A morning zero tape will automatically print from the ballot scanner. **DO NOT SIGN OR REMOVE THE MORNING ZERO TAPE!** It must remain attached to the ballot scanner until after the polls close.

5:15:11 AM

Precinct 0001, Ward 51
Current ballots cast = 000

Polls open, OK to read ballots

23-F

- E. After the zero tape prints, the message "ALL CHECKSUMS O.K." must appear on the tape under the date of the election and the time of day.
- F. Review the bottom of the tape. The following information should appear:
- date of election and time of day
 - precinct and ward
 - current ballots cast = 000
 - polls open, OK to read ballots
- G. Every judge should become familiar with the override button. It is visible through the hole in the door on the back of the ballot scanner and is the number 3 on the keypad.

This button will be pressed if a voter wants to override an overvoted or blank ballot.

- H. The green "Ready to Read Ballots" light should be ON. This means the ballot scanner is ready to accept ballots. Close and lock the rear door of the ballot scanner and place key back in the blue supply box.
- I. Verify that the public counter is at 0000. Once the voting begins, the public counter will count the number of ballots that

have been accepted by the ballot scanner. After the first ballot is accepted, the paper tape will print a message and advance the paper. It will not print or advance for every ballot accepted there-after, unless a ballot error is detected.

- J. The paper tape will display messages to the judges on how to process overvoted, undervoted, blank, uninitialed, defective or jammed ballots.

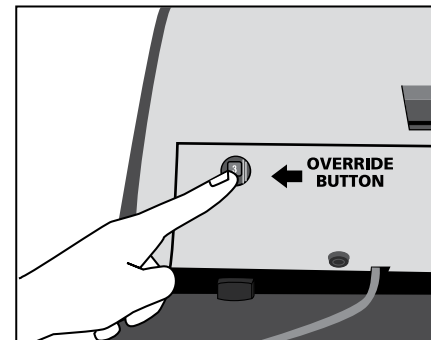

23-G

15. SET UP OF TOUCHSCREEN VOTING UNIT (One judge and the polling place administrator must setup the touchscreen)

Removal of Audio Components, Leg Assembly and Power Cord

- A. The touchscreen should be placed on a table or the floor with the storage covers facing up. The storage covers are marked "Audio", "Leg Assembly" and "Power Cord". Also, the yellow and black holes will be facing up.



- B. Remove each cover and remove the contents. Replace the covers. Unit should remain on the floor or table. Place power cord, strap and audio headphones to the side.

Assembly of Legs

NOTE: The leg assembly is a one-piece unit.

- A. Pull the leg assembly apart so that the upper brace is fully extended and the lower brace is bent upward. AT THIS POINT, THE UPPER AND LOWER BRACES ARE NOT CONNECTED.
- B. Place the black bottom ends into the black slots. Place the yellow bottom ends into the yellow slots. Press the legs into the slots until you hear a "click".
- C. Once the legs are securely in place, insert the pin located on the upper brace into the hole located on the lower brace. The braces should resemble an "X".
- D. Extend the lower portions of each leg until the retention pins "click" into place. Make sure the legs are completely extended.

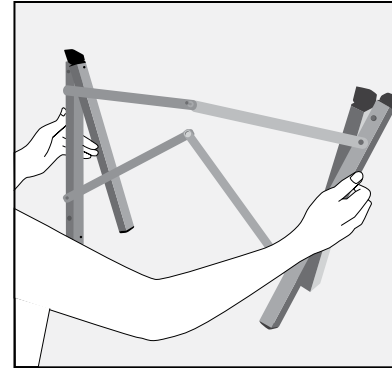

24-A

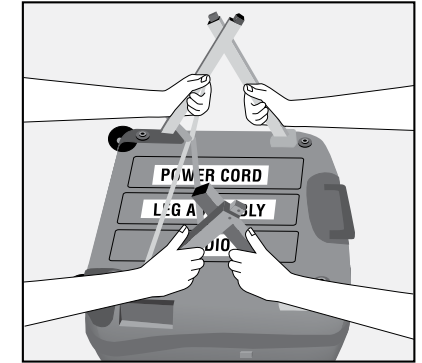

24-B

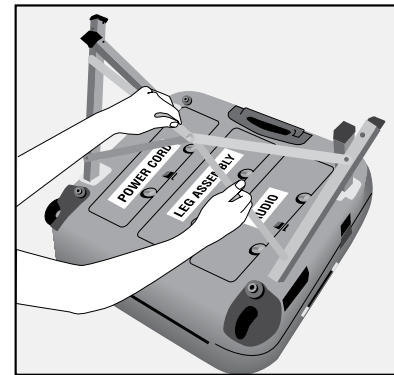

24-C

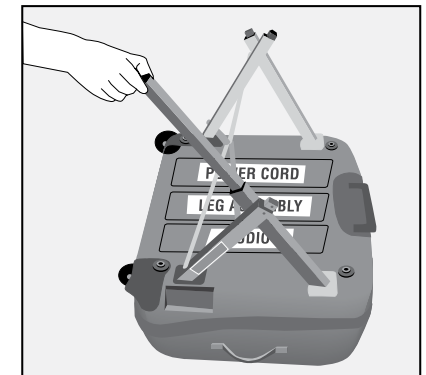

24-D

- E. A judge and the PPA should carefully roll the unit on its side with the main handle facing up and then lift the unit off the floor or table and onto its legs.

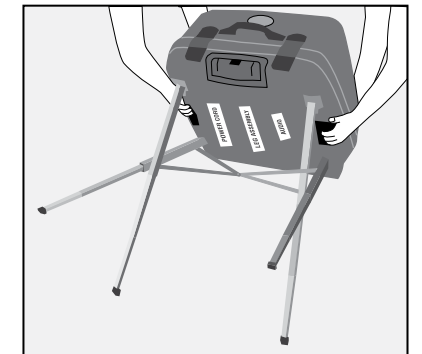

24-E

Opening the touchscreen unit

- A. Unfasten the four latches and remove the lid. Each latch has a silver locking tab, which must be pushed to the left for the latch to be unlocked. Place the lid inside the ESC.
- B. Remove the privacy panels and curtain from the unit and set aside.

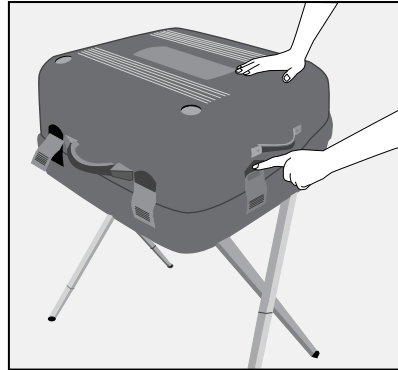

25-A

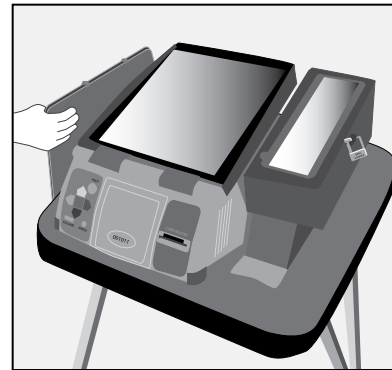

25-B

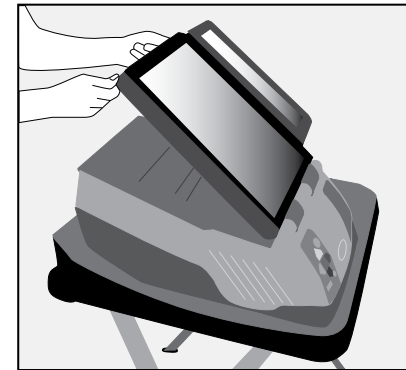

25-C (1)

The printer will remain attached to the touchscreen. Make sure the cable is securely plugged into the printer and the touchscreen.

Verify that the seal number located on the seal affixed to the printer is the same as on the Seal Accountability Form. Do not break the seal at this point. **If the seal number is not the same or if the seal is missing, call EQUIPMENT/SUPPLIES at 773-247-4065 immediately.**

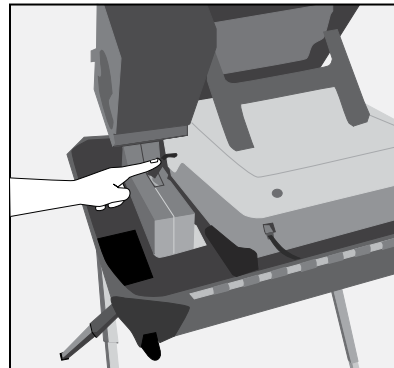

25-C (2)

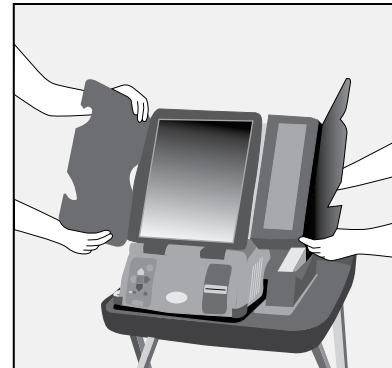

25-D (1)

- C. Gently raise the screen and printer and place the positioning bar in the second position. Printer cable should be plugged into both the printer and touchscreen.
- D. Attach the left privacy panel to the left side of the touchscreen.

Attach the right privacy panel to the right side of the printer. You will hear a click when the privacy panels are completely inserted. Using the Velcro, attach the privacy curtain to the top portion of the privacy panels. The privacy curtain should be attached so that the flap covers the back of the touchscreen and printer.

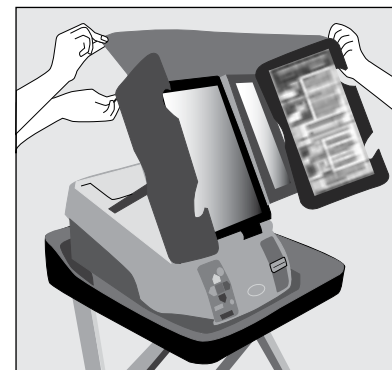

25-D (2)



25-D (3)

Powering Up the Touchscreen

A. Plug the power cord into the right side of the touchscreen then into either a wall outlet or extension cord. Make sure the cord will not cause a voter to trip and fall or impede the passage of a voter using a wheelchair. Use tape to secure the cord to the floor, if necessary. Once the unit is plugged in, the green AC ON light must be lit, if not, plug into a different outlet. The AC ON light is located above the plug on the right side of the unit.

B. Verify that the seal number located on the seal affixed to the cartridge ports door is the same as on the Seal Accountability Form. Do not break the seal at this point. **If the seal number is not the same or if the seal is missing, call EQUIPMENT/SUPPLIES at 773-247-4065 immediately.**

Verify that the seal number located on the seal affixed to the Polls Open/Close door is the same as on the Seal Accountability Form. Do not break the seal at this point. **If the seal number is not the same or if the seal is missing, call EQUIPMENT/SUPPLIES at 773-247-4065 immediately.**

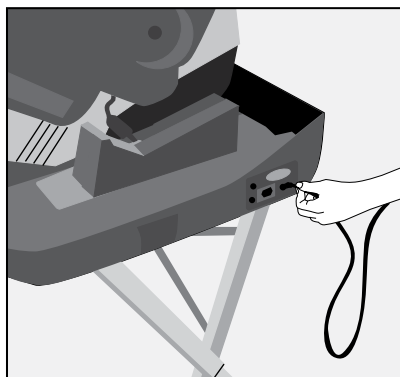

26-A

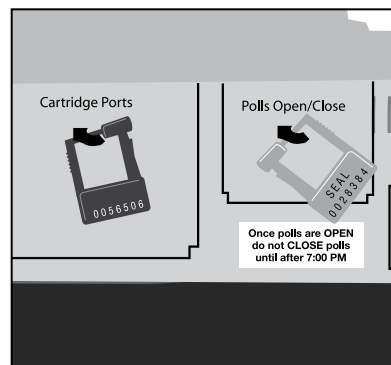

26-B

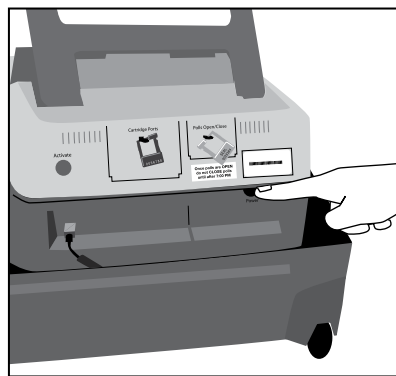

26-C

C. Press the red Power switch located on the back of the unit. The unit will take a few minutes to power up. Wait for instructions that will appear on the screen.

D. When the message **“Ready to Open Official Election Polls. To begin voting move the dial to OPEN”** appears on the screen, break the yellow seal on the Polls Open/Close door, remove the red seal and turn the dial to OPEN.

E. Verify that the seal number located on the red seal that was under the Polls Open/Close door is the same as on the Seal Accountability Form. Place the red seal on the Polls Open/Close Door. **If the seal number is not the same or if the seal is missing, call EQUIPMENT/SUPPLIES at 773-247-4065 immediately.**

F. Once the polls have been opened, an Official Zero Proof Report will print on the printer. **DO NOT PRESS THE “ZERO PROOF REPORT” BUTTON.** Verify that your precinct and ward is printed on the zero tape.

Important: The polls must remain OPEN all day. Make sure the red seal is placed on the door.

The Official Zero Proof Report must not be removed from the printer at this point. Make sure the pollwatchers in your precinct view the zero tape.

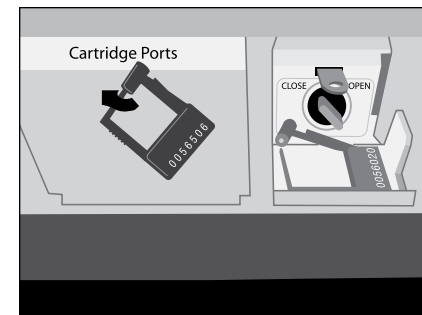

26-E

G. After the zero proof report finishes printing, the screen will display the message “Waiting For First Voter”. Touch “Start Voting”.

H. You will notice two green lights on the front of the touchscreen, one on the printer and one below the screen. If the green light on the printer is flashing have the PPA correct the problem or call EQUIPMENT/SUPPLIES at 773-247-4065.

I. Verify that the public counter located at the bottom of the screen shows 0. If not, call EQUIPMENT/SUPPLIES at 773-247-4065.

J. The front of the touchscreen should be facing a wall, so that the voter can have privacy while voting.

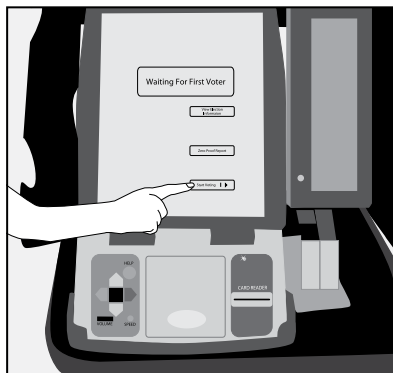

27-G



27-H

Attaching the Audio Headphones

NOTE: ONLY ATTACH THE HEADPHONES WHEN A VOTER IS USING THE AUDIO BALLOT. DO NOT LEAVE HEADPHONES PLUGGED INTO THE CONTROLLER ALL DAY.

THE AUDIO CONTROLLER IS ATTACHED TO THE TOUCHSCREEN. IT MUST BE PULLED OUT FROM THE UNIT TO USE. THE VOTER HOLDS THE AUDIO CONTROLLER WHILE VOTING.

Follow these steps when a voter requests an audio ballot:

- A. Lift the audio controller away from the unit. Plug the headphones into the bottom of the controller.
- B. Place a set of headphone covers on the headphones. After the voter uses the headphones, remove and dispose of the used covers and replace with new covers. Place the remaining headphone covers at Station #3.
- C. The headphones can be placed on the back of the unit when not in use by a voter.

Please see page 51 for information on activating an audio ballot.

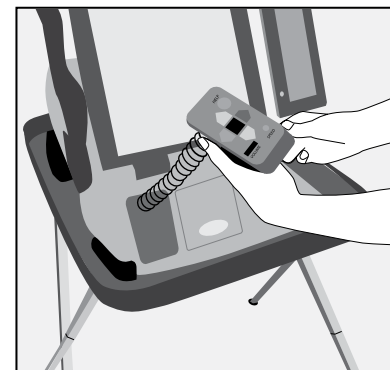

27-A

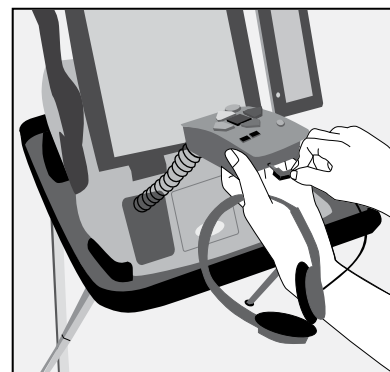

27-A

16. SETTING UP THE VOTER CARD ACTIVATOR

The voter card activator has a message window that will display messages to the judges of election. Some of the messages will remain until they are cleared by the judges. Press either YES or NO to clear the screen.

- A. Verify that the voter card activator is for the correct precinct and ward by looking at the sticker located on the unit.

If the voter card activator is not for your precinct, immediately call EQUIPMENT/SUPPLIES at 773-247-4065.

- B. Verify that the seal number located on the seal affixed to the printer is the same as on the Seal Accountability Form. Do not break the seal at this point. **If the seal number is not the same or if the seal is missing, call EQUIPMENT/SUPPLIES at 773-247-4065 immediately.**

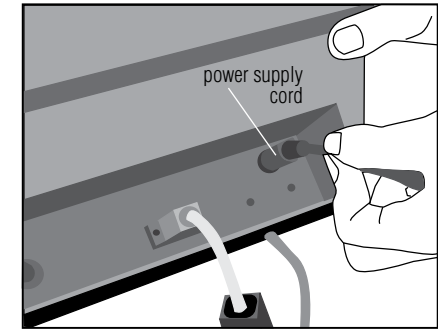

28-B

- C. The power cord and power supply should be attached. The power supply is plugged into the back of the unit and the power cord should be plugged into either a wall outlet or extension cord.

- D. There is no door covering the power switch.

Raise the antenna and turn the unit ON. The voter card activator will be used to activate voter cards for the touchscreen during Election Day. It must remain ON all day. If the Board of Elections does not receive a signal indicating that the voter card activator is ON, the Board will contact the cell phone judge or polling place administrator and instruct you to turn the unit ON.

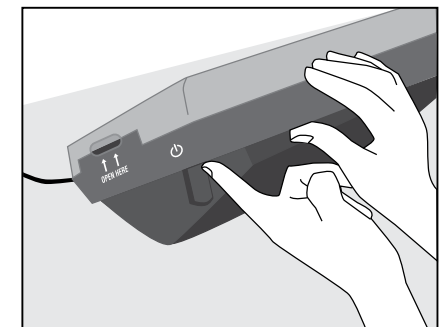

28-C

VOTER CARD ACTIVATOR

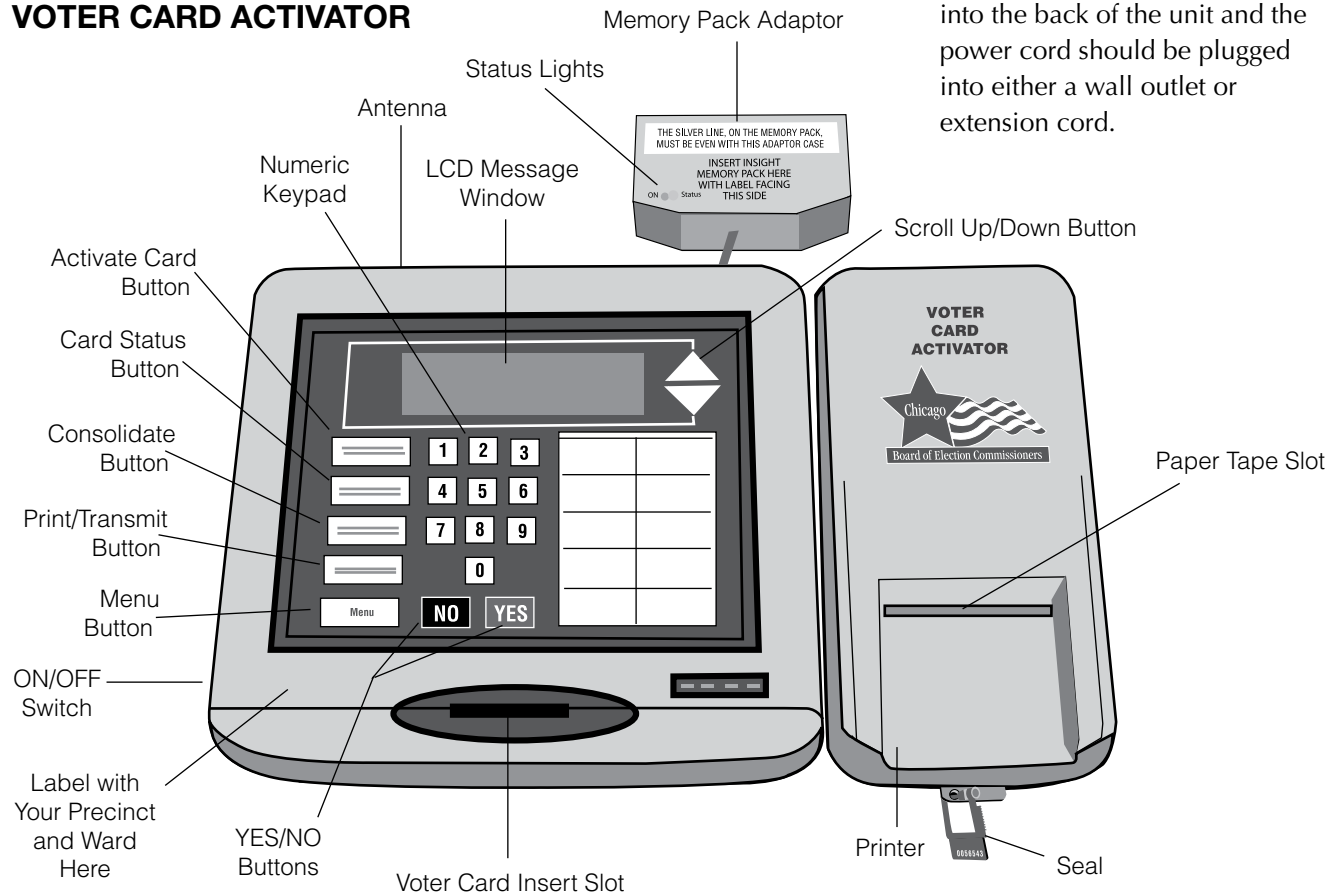

NOTE: The voter card activator is pre-programmed. You will not insert the memory devices until after 7 pm. After the polls close, the voter card activator will be used to transmit the results from the touchscreen and ballot scanner.

- E. The voter card activator will take a few minutes to power up.
- F. After the unit is powered up, press “Menu”, then the number 5 (print), then the number 4 (zero report), then the number 1 (all precincts). A zero report will begin to print. Remove the zero report and place inside the transfer case.

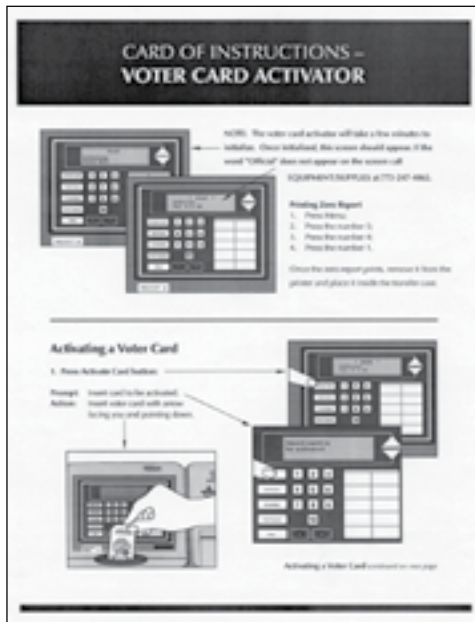

- G. Remove the voter cards from the blue supply box and place next to the voter card activator. Each precinct is being supplied with 5 voter cards, which can be reactivated during Election Day. It is important that the voters are instructed to return the voter cards to the judges after voting. **Do not pre-activate voter cards. Voter cards should only be activated after the voter has been verified.**
- H. Make sure the card of instructions is placed next to the voter card activator.



25-F

16. POST ALL SIGNS CONTAINED IN ENVELOPE 2

- Form 25 “Information and Services” sign
- Form 177 “Polling Place” sign (double sided, use the Accessible side only if a polling place is accessible by wheelchair)
- Form 177A “Accessible Entrance” sign (if applicable, please ensure the entrance is accessible by wheel chair before you post this sign)
Please post at the height someone using a wheelchair will see
- Form 177AE “Alternate Entrance” sign (if applicable)
- Form 250 “We Speak Your Language” sign
- Form 251 “ID Required” sign
- Form 253 “Voter’s Bill of Rights” sign
- Form 255 “Voting Instructions” sign
- Form 255P “Provisional Voting Information” sign
- **NEW** Election Day Voter Registration Sign

Information and Services / जानकारी और सेवाएँ Información y Servicios / 資訊與服務



Precinct (選區) (選區) _____ Ward (區) (區) _____



Ballots are printed on recycled paper. If you wish to use the Official Ballot Book and ballot envelopes, you will not receive a sample or ballot envelope. If you wish to receive a sample ballot envelope, you will not receive the Official Ballot Book and ballot envelopes. If you wish to receive a sample ballot envelope, you will not receive the Official Ballot Book and ballot envelopes.

Ballots are printed on recycled paper. If you wish to use the Official Ballot Book and ballot envelopes, you will not receive a sample or ballot envelope. If you wish to receive a sample ballot envelope, you will not receive the Official Ballot Book and ballot envelopes.

Ballots are printed on recycled paper. If you wish to use the Official Ballot Book and ballot envelopes, you will not receive a sample or ballot envelope. If you wish to receive a sample ballot envelope, you will not receive the Official Ballot Book and ballot envelopes.

Ballots are printed on recycled paper. If you wish to use the Official Ballot Book and ballot envelopes, you will not receive a sample or ballot envelope. If you wish to receive a sample ballot envelope, you will not receive the Official Ballot Book and ballot envelopes.

Ballots are printed on recycled paper. If you wish to use the Official Ballot Book and ballot envelopes, you will not receive a sample or ballot envelope. If you wish to receive a sample ballot envelope, you will not receive the Official Ballot Book and ballot envelopes.

Ballots are printed on recycled paper. If you wish to use the Official Ballot Book and ballot envelopes, you will not receive a sample or ballot envelope. If you wish to receive a sample ballot envelope, you will not receive the Official Ballot Book and ballot envelopes.

Ballots are printed on recycled paper. If you wish to use the Official Ballot Book and ballot envelopes, you will not receive a sample or ballot envelope. If you wish to receive a sample ballot envelope, you will not receive the Official Ballot Book and ballot envelopes.

Ballots are printed on recycled paper. If you wish to use the Official Ballot Book and ballot envelopes, you will not receive a sample or ballot envelope. If you wish to receive a sample ballot envelope, you will not receive the Official Ballot Book and ballot envelopes.

Ballots are printed on recycled paper. If you wish to use the Official Ballot Book and ballot envelopes, you will not receive a sample or ballot envelope. If you wish to receive a sample ballot envelope, you will not receive the Official Ballot Book and ballot envelopes.

Ballots are printed on recycled paper. If you wish to use the Official Ballot Book and ballot envelopes, you will not receive a sample or ballot envelope. If you wish to receive a sample ballot envelope, you will not receive the Official Ballot Book and ballot envelopes.

Ballots are printed on recycled paper. If you wish to use the Official Ballot Book and ballot envelopes, you will not receive a sample or ballot envelope. If you wish to receive a sample ballot envelope, you will not receive the Official Ballot Book and ballot envelopes.

Ballots are printed on recycled paper. If you wish to use the Official Ballot Book and ballot envelopes, you will not receive a sample or ballot envelope. If you wish to receive a sample ballot envelope, you will not receive the Official Ballot Book and ballot envelopes.

Judges: Immediately post this sign in a prominent

Bill of Rights for All Voters

Declaración de Derechos Para Todos los Votantes

選民權利法案 所有選民應有的權利

You have a right to:

1. Use your ballot in a non-disruptive atmosphere free of interference.

United States Constitution
Article I, Section 2, Clause 3

Article I, Section 2, Clause 3

Article I, Section 2, Clause 3

Article I, Section 2, Clause 3

Article I, Section 2, Clause 3

Article I, Section 2, Clause 3

Article I, Section 2, Clause 3

Article I, Section 2, Clause 3

Article I, Section 2, Clause 3

Article I, Section 2, Clause 3

Article I, Section 2, Clause 3

Article I, Section 2, Clause 3

Article I, Section 2, Clause 3

Article I, Section 2, Clause 3

Article I, Section 2, Clause 3

Article I, Section 2, Clause 3

Article I, Section 2, Clause 3

Article I, Section 2, Clause 3

Article I, Section 2, Clause 3

Article I, Section 2, Clause 3

Article I, Section 2, Clause 3

Article I, Section 2, Clause 3

Article I, Section 2, Clause 3

Provisional Voting Information

Información Para Votación Provisional 臨時投票資訊

अस्थायी मतदान जानकारी

Section 1: [Text in multiple languages]

Section 2: [Text in multiple languages]

Section 3: [Text in multiple languages]

Section 4: [Text in multiple languages]

Section 5: [Text in multiple languages]

Section 6: [Text in multiple languages]

Section 7: [Text in multiple languages]

Section 8: [Text in multiple languages]

Section 9: [Text in multiple languages]

Section 10: [Text in multiple languages]

Section 11: [Text in multiple languages]

Section 12: [Text in multiple languages]

Section 13: [Text in multiple languages]

Section 14: [Text in multiple languages]

Section 15: [Text in multiple languages]

Section 16: [Text in multiple languages]

Section 17: [Text in multiple languages]

Section 18: [Text in multiple languages]

Section 19: [Text in multiple languages]

Section 20: [Text in multiple languages]

Section 21: [Text in multiple languages]

Section 22: [Text in multiple languages]

Section 23: [Text in multiple languages]

Section 24: [Text in multiple languages]

Section 25: [Text in multiple languages]

Section 26: [Text in multiple languages]

Section 27: [Text in multiple languages]

Section 28: [Text in multiple languages]

Section 29: [Text in multiple languages]

Section 30: [Text in multiple languages]

Election Day Voter Registration

Registración de Votante en el Día de Elección

選民日與投票登記 選民日與投票登記



November 4, 2014
6:00 am to 7:00 pm

Noviembre 4, 2014
6:00 am a 7:00 pm

2014年11月4日
上午6:00至下午7:00時

4 नवम्बर, 2014
सां 6.00 बजे - सां 7.00 बजे

Board of Election Commissioners	80 W. Washington St. 8th Floor
Dr. Martin Luther King Jr. Community Center	4314 S. Cottage Grove
Mount Greenwood Park	3731 W. 111th St.
West Side Learning Center	4024 W. Madison St.
Waters Park	2333 W. Sunnyside Ave.

Visit any one of the above locations to register to vote/poll on Election Day. Please bring two pieces of acceptable identification with you including one with your current address.

Visit any one of the above locations to register to vote/poll on Election Day. Please bring two pieces of acceptable identification with you including one with your current address.



For more information, visit our website at www.chicagovote.com

For more information, visit our website at www.chicagovote.com

For more information, visit our website at www.chicagovote.com

For more information, visit our website at www.chicagovote.com

For more information, visit our website at www.chicagovote.com

For more information, visit our website at www.chicagovote.com

For more information, visit our website at www.chicagovote.com

"We Speak Your Language!"
Verbal assistance in the electoral process is available in several languages including Spanish, Chinese, Polish and Hindi. Call Election Central 312-269-7870

"¡Nosotros Hablamos Su Idioma!"
Asistencia verbal en el proceso electoral es disponible en varios idiomas incluyendo Español, Chino, Polaco e Hindi. Llame a la Central de Elecciones al 312-269-7870

"我們說您的語言！"
在選舉過程中可提供多種語言協助。這些語言包括西班牙文、中文、波蘭文及印度文。致電選舉中心 312-269-7870

"MÓWIEMY W TWOIM JEZYKU!"
Pomoc w procesie wyborczym jest dostępna w kilku językach między innymi hiszpańskim, chińskim, polskim i hindi. Dzwonić – Centralne Biuro Wyborów 312-269-7870

"हम आपकी भाषा बोलते हैं!"
चुनावी प्रक्रिया में बोलिक सहायता स्पेनिश, चीनी, पोलिश, हिन्दी सहित कई और सरकारी से उपलब्ध है। रिश्तकर केंद्र को 312-269-7870 पर फोन करें